



# Broadcast and Entertainment Products ProAx™ Triaxial Camera Connectors Installation Instructions

Content	Page
1 GENERAL INFORMATION .....	2
1.1 Standard Tools .....	3
1.2 ADC ProAx Triaxial Cable Strip Gauge .....	3
1.3 ProAx Triaxial Connector Components .....	4
2 ASSEMBLY PROCEDURE FOR ProAx TRIAXIAL CONNECTOR JACK AND PLUG .....	6
3 CUSTOMER INFORMATION AND ASSISTANCE .....	11

## INTRODUCTION

This manual provides the procedure for installing ADC’s ProAx™ Triaxial Camera Connectors on triaxial cables. Because assembly of the ProAx triaxial connectors differs from the assembly of other triaxial connectors, it is very important that this procedure be closely followed.

## Revision History

ISSUE	DATE	REASON FOR CHANGE
Issue 1	01/2000	Original

## Trademark Information

ADC and ADC Telecommunications are registered trademarks of ADC Telecommunications, Inc. ProAx is a trademark of ADC Telecommunications, Inc.

## Admonishments

Important safety admonishments are used throughout this manual to warn of possible hazards to persons or equipment. An admonishment identifies a possible hazard and then explains what may happen if the hazard is not avoided. The admonishments — in the form of Dangers, Warnings, and Cautions — must be followed at all times. These warnings are flagged by use of the triangular alert icon (seen below), and are listed in descending order of severity of injury or damage and likelihood of occurrence.



**Danger:** *Danger is used to indicate the presence of a hazard that **will** cause severe personal injury, death, or substantial property damage if the hazard is not avoided.*



**Warning:** *Warning is used to indicate the presence of a hazard that **can** cause severe personal injury, death, or substantial property damage if the hazard is not avoided.*



**Caution:** *Caution is used to indicate the presence of a hazard that **will** or **can** cause minor personal injury or property damage if the hazard is not avoided.*

## 1 GENERAL INFORMATION

The use of this procedure will help to ensure correct assembly and reliable operation of the ProAx triaxial connectors. The connector assembly procedure in this manual is intended to be used for assembling all sizes of female ProAx triaxial jacks and all sizes of male ProAx triaxial plugs.

► **Note:** Because assembly of the ProAx triaxial connectors is different than the assembly of other manufacturers' triaxial connectors, please follow this assembly procedure closely.

### 1.1 Standard Tools

The ProAx triaxial connectors can be assembled using standard, common tools. A measuring tape or ruler and pen or marker are used to measure and mark the amount of cable jacket, dielectric, and braid to cut. Tape, such as plastic electrical tape or masking tape is also used to hold the outer braid in place during the assembly procedure. The standard tools are shown in Figure 1.

### 1.2 ADC ProAx Triaxial Cable Strip Gauge

An optional ADC ProAx triaxial cable strip gauge may be used to measure and hold the cable when cutting the cable jacket, dielectric, and braid. The optional ADC ProAx triaxial cable strip gauge is shown in Figure 2.

To use the optional ADC ProAx triaxial cable strip gauge in the following connector assembly procedure, insert the cable into the slot in the gauge corresponding to the operation to be performed. Insert the cable to the end of the slot against the wall in the slot. Then cut the cable jacket, dielectric, or braid at the edge of the gauge, parallel to the edge of the gauge, all around the cable.

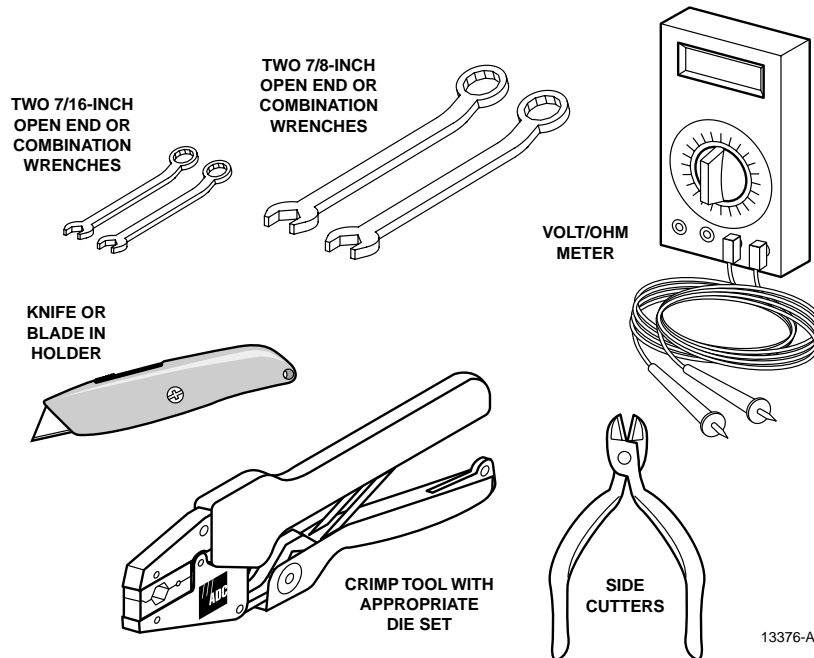

Figure 1. Standard Tools Used for ProAx Triaxial Connector Assembly

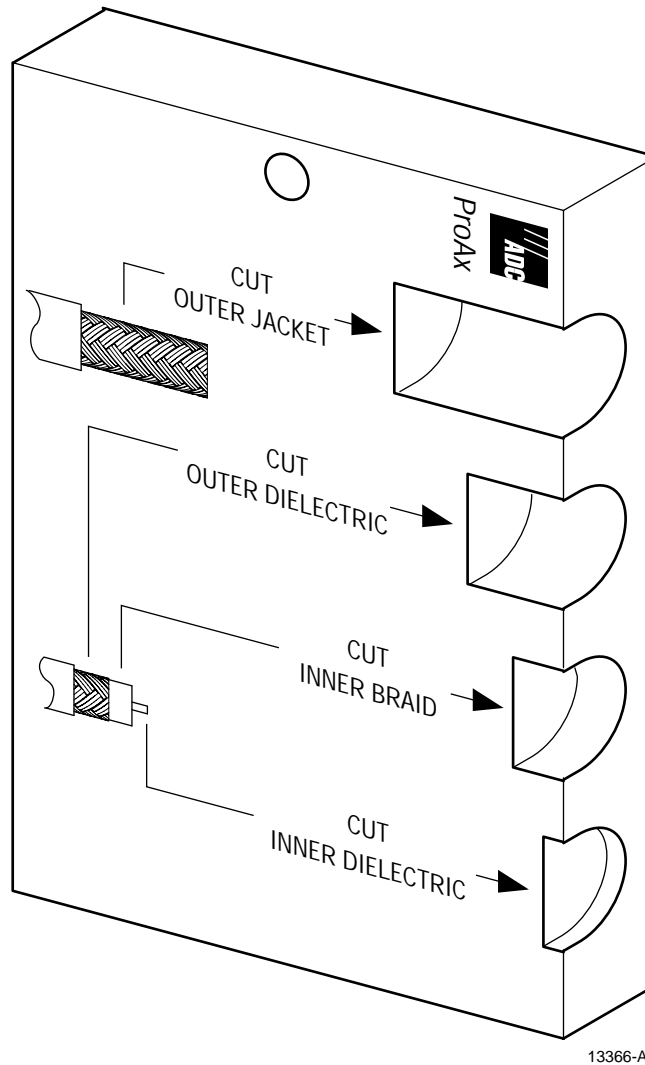

Figure 2. ADC ProAx Triaxial Cable Strip Gauge

### 1.3 ProAx Triaxial Connector Components

The ProAx triaxial connector consists of the individual parts shown in Figure 3. Also shipped with the ProAx triaxial connector is an installation drawing. The installation drawing can also be referred to when assembling the connector.

Some parts are partially assembled or are placed within other parts for shipping. Before beginning assembly of the ProAx triaxial connector, remove all parts from the shipping bags and separate all parts. Unscrew the rear end cap from the front connector body and remove the ground washer and outer conductor insulator from the inside of the front connector body. Remove the o-ring and the rear seal ring from inside the rear end cap.

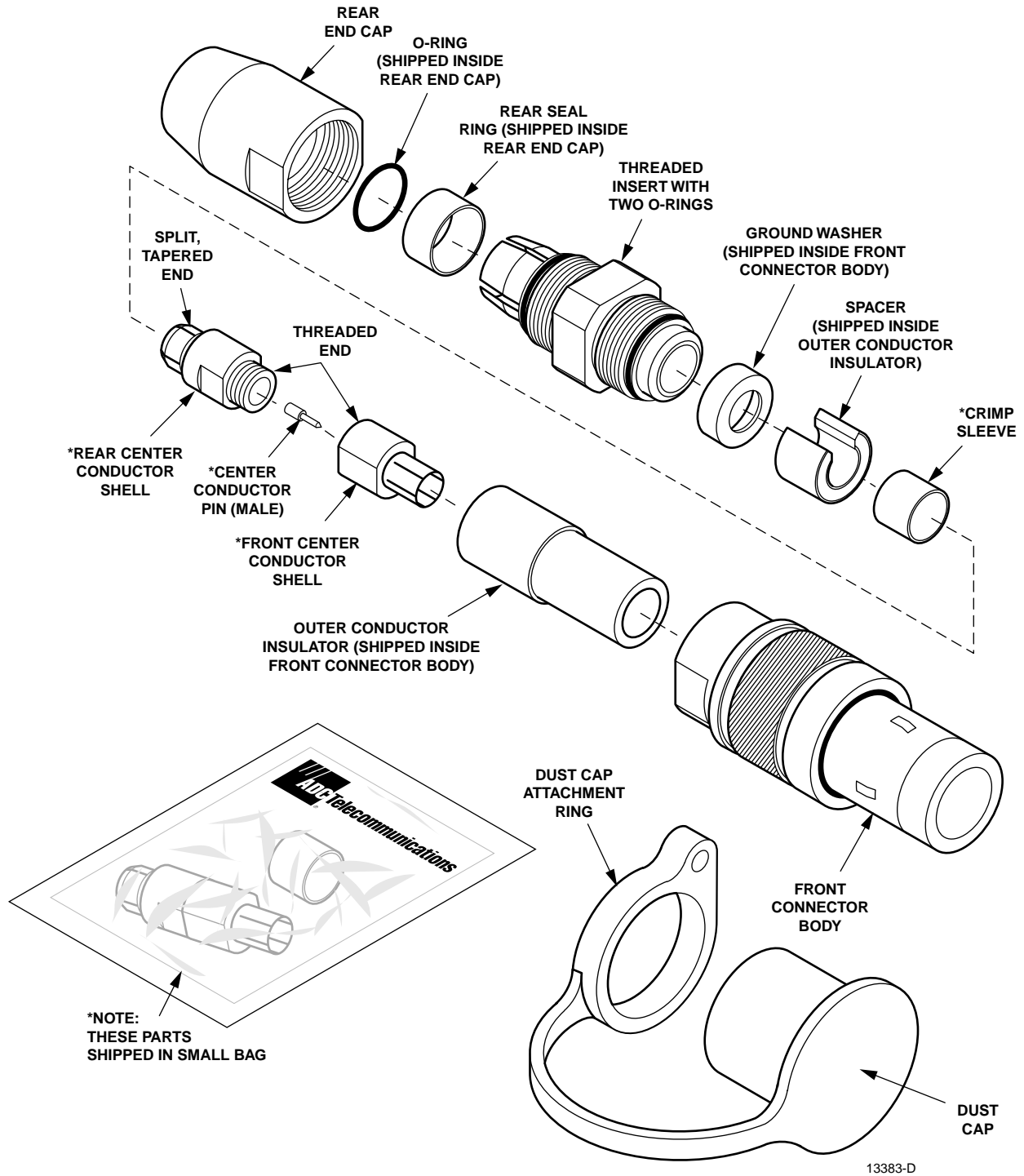
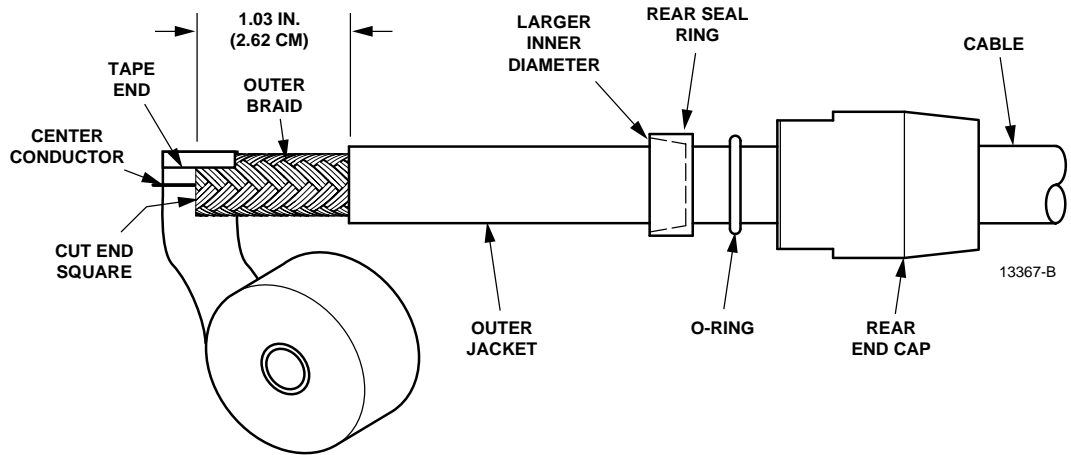

Figure 3. ProAx Triaxial Connector Components, Male Connector Components Shown

## 2 ASSEMBLY PROCEDURE FOR ProAx TRIAXIAL CONNECTOR JACK AND PLUG

Assemble the ProAx triaxial connector on the corresponding size of triaxial cable by performing the following steps:

1. Using the blade (blade in holder or knife), cut the end of the cable off as square to the cable as possible. See Figure 4.
2. Slide the rear end cap onto the cable. Slide the o-ring onto the cable. Slide the rear seal ring over the outer jacket of the cable with the larger inner diameter (thinner ring wall) facing towards the cut end of the cable. See Figures 3 and 4.



**Figure 4. Rear Seal Ring, O-Ring, and Rear End Cap on Cable; and Outer Jacket Cut Dimensions**

3. Using the blade, cut a 1.031 inch length of the outer jacket from the cable (see dimensions in Figure 4). Cut off the outer jacket only, evenly around the cable.
 

If using the ADC triaxial cable strip gauge, place the end of the cable in the slot labeled, CUT OUTER JACKET. Push the end of the cable against the end of the slot. Cut the outer jacket only, evenly around the cable, at the edge of the gauge (parallel to the gauge edge).

◆ **Note:** Be careful to not cut deeper than the outer jackets so that the outer braid is not cut or nicked.
4. After removing the outer jacket, wrap tape around the outer braid (shield) to prevent the braid from fraying and breaking. See Figure 4.
5. Slide the threaded insert (see Figure 3) over the tape and outer braid. Push the end of the threaded insert against the outer dielectric (inner jacket and insulation) until it is seated. See Figure 5.
 

◆ **Note:** **Do not tighten any parts that are on the cable together at this time.** This will be done later in this procedure.
6. Remove the tape from the end of the cable. Pull back the outer braid and comb it out over the threaded insert (see Figure 5).

7. Using the side cutters, trim excess braid so that the braid only reaches to the lip (raised edge next to o-ring) of the threaded insert. See Figures 5 and 6.

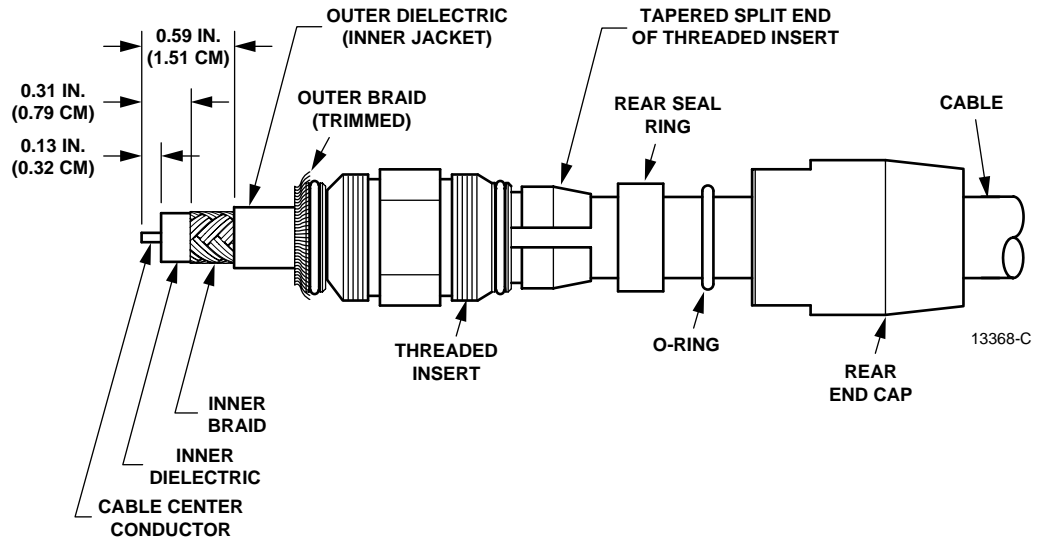

Figure 5. Outer Dielectric, Inner Braid, and Inner Dielectric Cut Dimensions; Threaded Insert on Cable

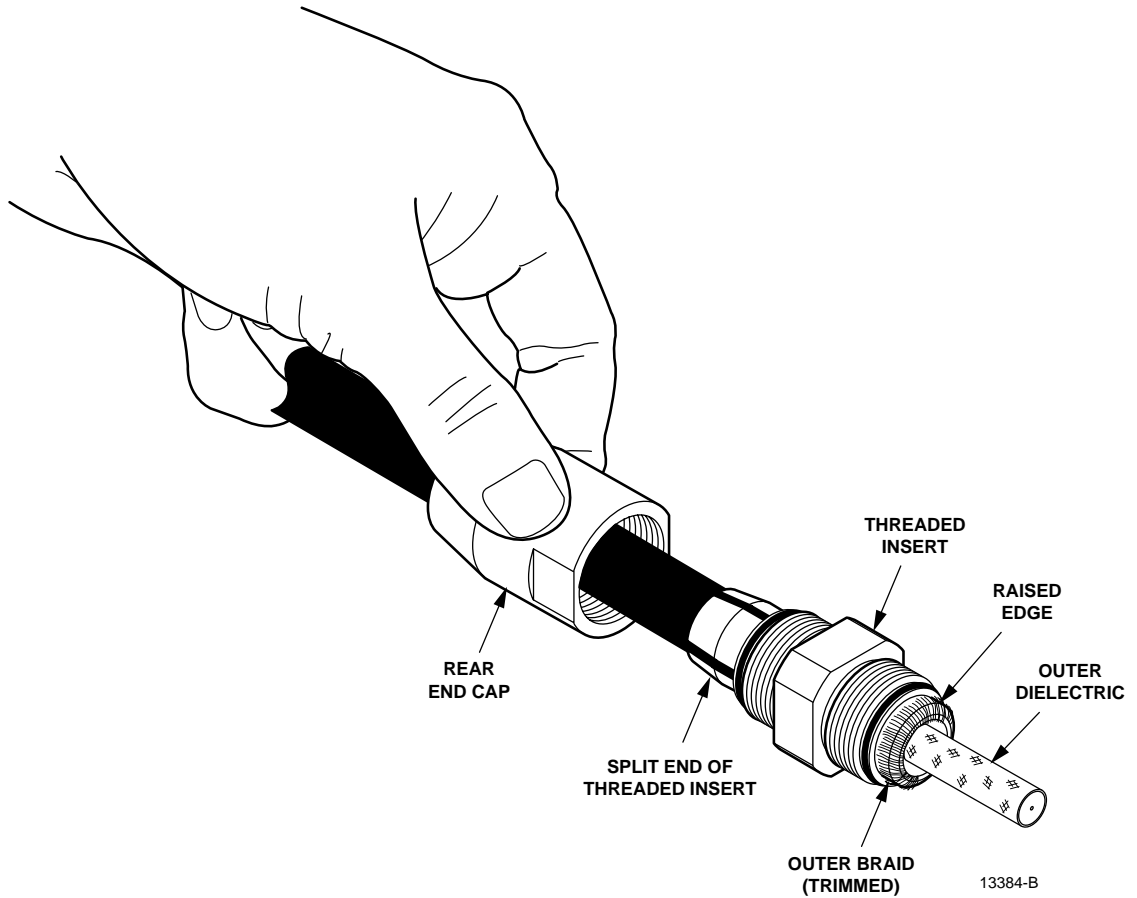
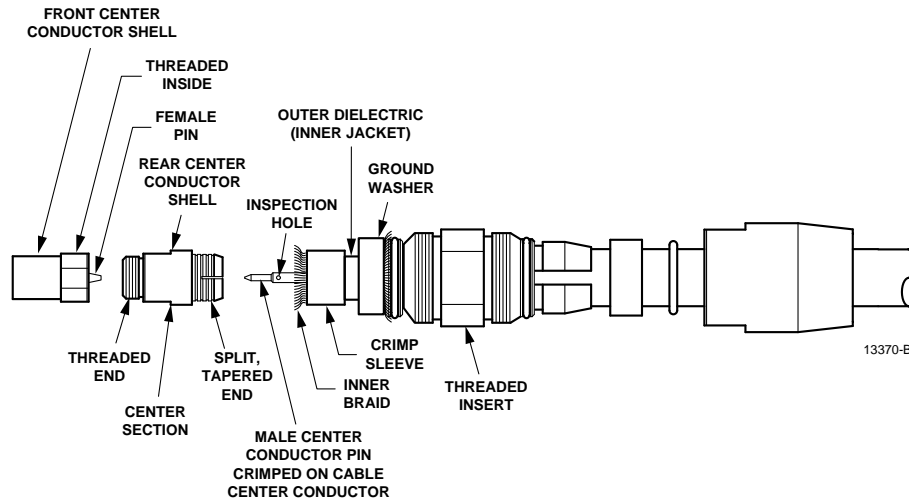

Figure 6. Cable with Outer Braid Over Threaded Insert, After Trimming

8. Slide the ground washer (see Figure 3) over the cable and push it against the trimmed braid and over the threaded insert (pushing the braid over the threaded insert). See Figure 7.



**Figure 7. Ground Washer Over Outer Braid, Center Conductor Pin Crimped on Cable Center Conductor**

9. Using the blade, remove the outer dielectric (inner jacket and insulation) so that the length from the end of the cable to the end of the outer dielectric is 0.593 inch (see dimensions in Figure 5). Cut the outer dielectric only, evenly around the cable.

If using the ADC ProAx triaxial cable gauge, place the end of the cable in the slot labeled, CUT OUTER DIELECTRIC. Push the end of the cable against the end of the slot. Cut the outer dielectric only, evenly around the cable, at the edge of the gauge.

► **Note:** Be careful to not cut or nick the inner braid.

10. Using the blade, remove the inner braid so that the length from the end of the cable to the end of the inner braid is 0.312 inch (see dimensions in Figure 5) Cut the inner braid only, evenly around the cable.

If using the ADC ProAx triaxial cable gauge, place the end of the cable in the slot labeled, CUT INNER BRAID. Push the end of the cable against the end of the slot. Cut the inner braid only, evenly around the cable, at the edge of the gauge.

► **Note:** Be careful to not cut or nick the inner dielectric under the braid.

11. Using the blade, remove the inner dielectric so that the length from the end of the cable to the end of the inner dielectric is 0.13 inch (see dimensions in Figure 5). Cut the inner dielectric only, evenly around the cable.

If using the ADC triaxial cable gauge, place the end of the cable in the slot labeled, CUT INNER DIELECTRIC. Push the end of the cable against the end of the slot. Cut the inner dielectric only, evenly around the cable, at the edge of the gauge.

► **Note:** Be careful to not cut or nick the center conductor under the inner dielectric.

12. Slide the center conductor pin (see Figure 3) over the center conductor of the cable, against the inner dielectric. See Figure 7.
  - ▶ **Note:** Be sure that the center conductor pin is fully seated against the inner dielectric and that the cable center conductor is visible through the inspection hole in the center pin (see Figure 7).
13. Using the smaller die in the crimp tool, align and crimp the center conductor pin onto the cable center conductor.
14. Slide the crimp sleeve (see Figure 3) over the inner braid and outer dielectric, up against the ground washer. See Figure 7.
15. Loosen and spread out the inner braid.
16. Slide the split, tapered end of the rear center conductor shell inside the crimp sleeve (pushing the inner braid inward between the rear center conductor shell and the crimp sleeve), twisting the rear center conductor shell as it is inserted.

Ensure that the inner braid is evenly distributed between the rear center conductor shell and the crimp sleeve, and that the crimp sleeve is against the raised center section of the conductor shell.

Adjust the position of the rear center conductor shell and crimp sleeve on the cable so that the center conductor pin is approximately flush with the threaded end of the rear center conductor shell and is centered in the conductor shell. See Figure 8.

Verify that the outer dielectric is visible between the crimp sleeve and the ground washer (see Figures 7 and 8).

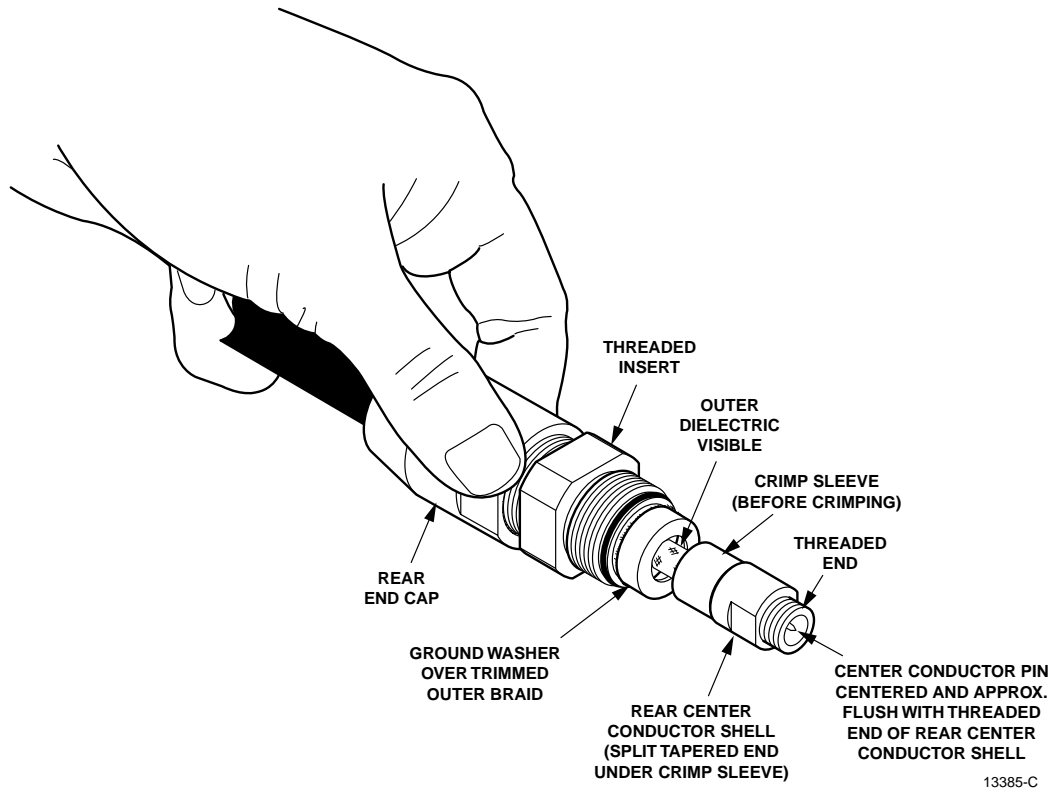

**Figure 8. Rear Center Conductor Shell and Crimp Sleeve Assembled with Outer Dielectric Visible**

17. Using the larger die in the crimp tool, crimp around the crimp sleeve See Figure 9.

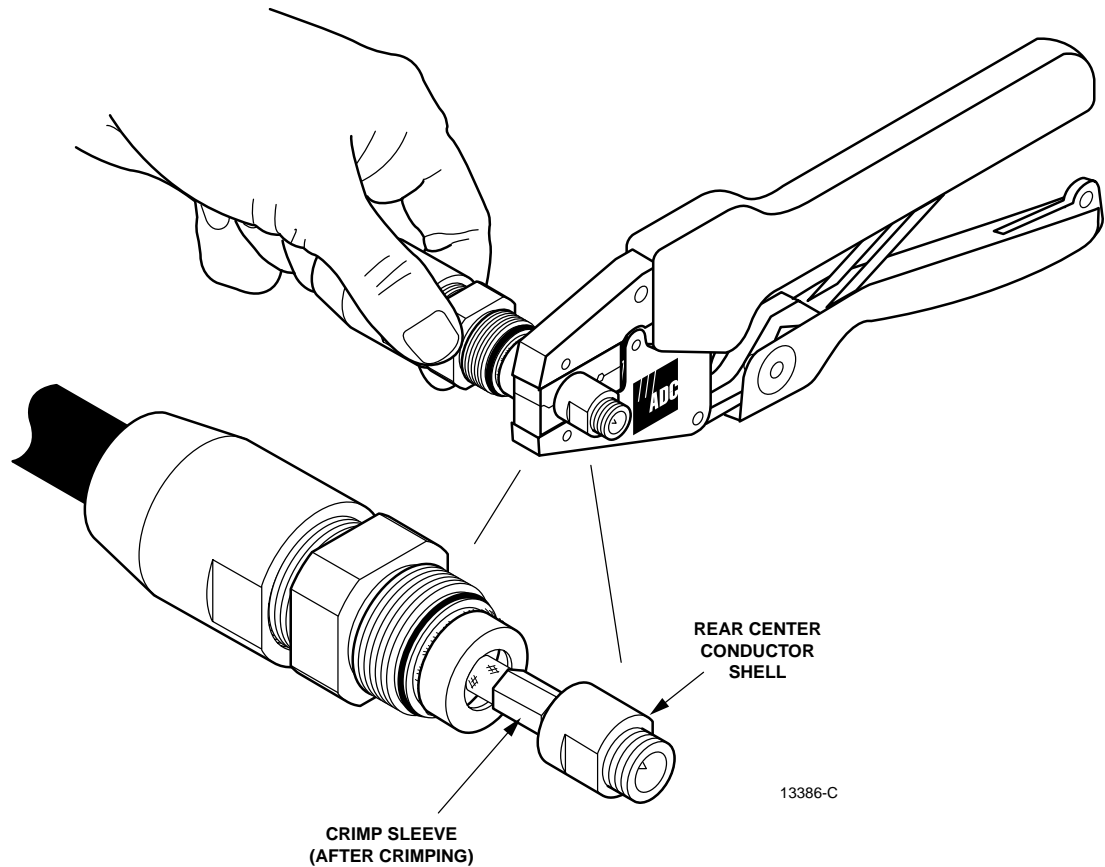
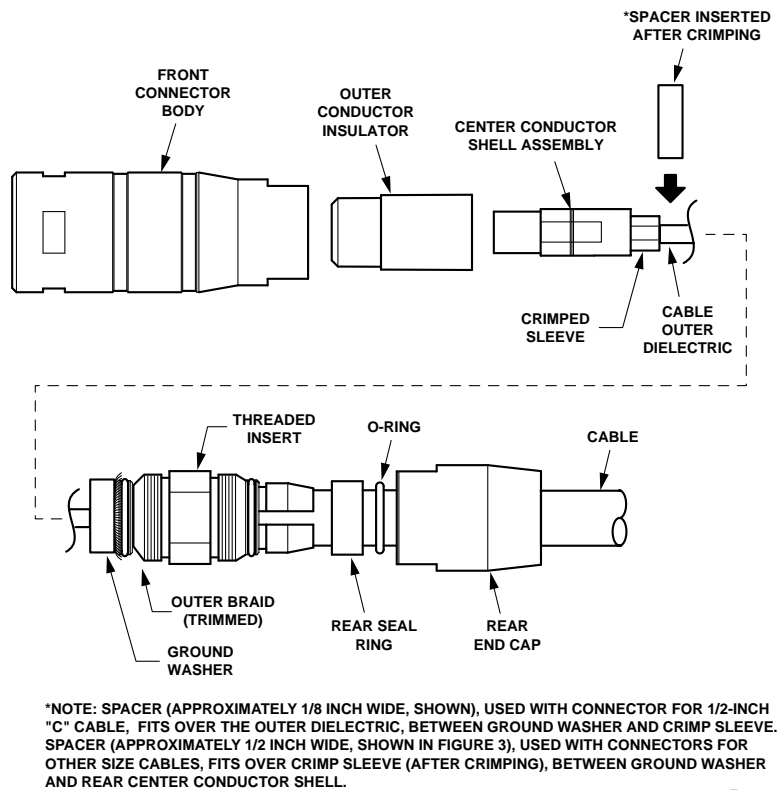

Figure 9. Crimping the Crimp Sleeve on the Inner Braid

18. Screw the front center conductor shell into the rear center conductor shell. Ensure that the male center conductor pin and the female pin in the front center conductor shell fit together correctly. See Figure 7.
19. Using two 7/16 inch open end wrenches, tighten the front and rear center conductor shell assembly. **Hold the rear shell stationary and turn the front shell.**
  - ▶ **Note:** Be sure that the center conductor pin is centered in the rear center conductor shell assembly.
20. If the connector is used for 1/2-inch “C” (0.520-inch) cable, insert the spacer (approximately 1/8 inch wide) over the outer dielectric, between the ground washer and the crimp sleeve. For connectors used with other sizes of cable, insert the spacer (approximately 1/2 inch wide) over the crimp sleeve (after crimping), between the ground washer and the center conductor shell assembly. See Figure 10.



**Figure 10. Connector Assembly, Showing Spacer and Outer Conductor Insulator Location**

21. Slide the outer conductor insulator (see Figure 3) over the center conductor shell assembly. See Figure 10. Ensure that the outer conductor insulator seats against the ground washer. If necessary, move the threaded insert and ground washer towards the outer conductor insulator.

Observe that, in a female connector assembly, the center conductor pin extends slightly beyond the end of the outer conductor insulator, and in a male connector assembly, the center conductor pin is flush with the end of the outer conductor insulator. If this is not observed, adjust position of the outer conductor insulator by moving the threaded insert and ground washer.

22. If necessary, trim excess outer braid that extends beyond the outer diameter of the ground washer as shown in Figure 10.
23. Slide the front connector body over the outer conductor insulator and ground washer, and screw onto the threaded insert.

Using two 7/8 inch open end wrenches, tighten the front connector body and the threaded insert. Hold the rear assembly (threaded insert) stationary and turn the front connector body.

24. Screw the rear end cap with the o-ring and rear seal ring over the threaded insert.
25. Using two 7/8 inch open end wrenches, tighten the rear end cap and the threaded insert. Hold the middle assembly (threaded insert) stationary and turn the rear end cap.

- ▶ **Note:** Tighten the rear end cap until the two assemblies are fully seated together and no threads are visible.

26. Using an ohmmeter, measure between each braid and measure between each braid and the center conductor for infinite resistance, assuring no short circuits between any conductors. Measure end to end continuity (low resistance) on all three conductors.
27. Place the dust cover attachment ring over the front connector body into the one of the grooves (either side of the knurling) on the front connector body.

### 3 CUSTOMER INFORMATION AND ASSISTANCE

For customers wanting information on ADC products or help in using them, ADC offers the services listed below. To obtain any of these services by telephone, first dial the central ADC telephone number, then dial the extension provided below.

The central number for calls originating in the U.S.A. or Canada is **1-800-726-4266**. For calls originating outside the U.S.A. or Canada, dial country code "1" then dial **612-946-3000**.

---

<b>Sales Assistance</b> <b>Extension 3000</b>	<ul style="list-style-type: none"> <li>• Quotation Proposals</li> <li>• Ordering and Delivery</li> <li>• General Product Information</li> </ul>
<b>BCG Technical Assistance Center</b> <b>Extension 3475</b> <b>E-Mail: <a href="mailto:technical@adc.com">technical@adc.com</a></b>	<ul style="list-style-type: none"> <li>• Technical Information</li> <li>• System/Network Configuration</li> <li>• Product Specification and Application</li> <li>• Training (Product-Specific)</li> <li>• Installation and Operation Assistance</li> <li>• Troubleshooting and Repair</li> </ul>
<b>Product Return Department</b> <b>Extension 3748</b> <b>E-Mail: <a href="mailto:repair&amp;return@adc.com">repair&amp;return@adc.com</a></b>	<ul style="list-style-type: none"> <li>• ADC Return Authorization number and instructions must be obtained before returning products.</li> </ul>

---

Product information may also be obtained using the ADC web site at **[www.adc.com](http://www.adc.com)** or by writing ADC Telecommunications, Inc., P.O. Box 1101, Minneapolis, MN 55440-1101, U.S.A.

Contents herein are current as of the date of publication. ADC reserves the right to change the contents without prior notice. **In no event shall ADC be liable for any damages resulting from loss of data, loss of use, or loss of profits and ADC further disclaims any and all liability for indirect, incidental, special, consequential or other similar damages. This disclaimer of liability applies to all products, publications and services during and after the warranty period.**

This publication may be verified at any time by contacting ADC's Technical Assistance Center at 1-800-366-3891, extension 3475 (in U.S.A. or Canada) or 612-946-3000 (outside U.S.A. and Canada), or by writing to ADC Telecommunications, Inc., Attn: Technical Assistance Center, Mail Station #71, P.O. Box 1101, Minneapolis, MN 55440-1101, U.S.A.

